

# CARES Technical Approval Report TA1B - 5027

Issue 3



**ERICO**

**LENTON<sup>®</sup>**  
Standard and Position Couplers

Assessment of the  
LENTON<sup>®</sup> Standard and  
Position Couplers Product,  
and Quality System  
for Production



TECHNICAL  
APPROVAL  
5027



002

# Product

LENTON® Standard and Position couplers A12, P13 and P14 for reinforcing steel

## Product approval held by:

ERICO  
Jules Verneweg 75,  
5015 BG,  
Tilburg,  
The Netherlands

## 1 Product Summary

The products are for the mechanical connection of deformed high-yield carbon steel bars for the reinforcement of concrete complying with the requirements of BS4449 grade B500B and grade B500C.

### 1.1 Scope of Application

LENTON® Standard couplers A12 have been evaluated for use as follows:

- A12 12mm - 50mm Static tension or compression applications in reinforced concrete structures designed to BS8110 or EC2 in accordance with CARES Appendix TA1-B using grade B500B and B500C reinforcement.

LENTON® Position couplers P13 and P14 have been evaluated for use as follows:

- P13/P14 12mm - 40mm Static tension or compression applications in reinforced concrete structures designed to BS8110 or EC2 in accordance with CARES Appendix TA1-B using grade B500B and B500C reinforcement.

### 1.2 Design Considerations

BS 8110 Clause 3.12.8.9 Laps and Joints states "Connections transferring stress may be lapped, welded or joined with mechanical devices. They should be placed, if possible, away from points of high stress and should preferably be staggered". BS 8110 Clause 3.12.8.16.2 states that a mechanical coupler satisfying the specified slip and tensile strength criteria is the only acceptable form of a full strength butt joint.



Eurocode 2, Clause 8.7 Laps and mechanical couplers 8.7.1 General (1)P "Forces are transmitted from one bar to another by:

- lapping of bars, with or without bends or hooks;
- welding;
- mechanical devices assuring load transfer in tension-compression or in compression only."

Clause 8.8 Additional rules for large diameter bars goes on to state that "Splitting forces are higher and dowel action is greater with the use of large diameter bars. Such bars should be anchored with mechanical devices."

The specified cover for fire resistance and durability should be provided to the coupler sleeve. All couplers have been designed with controlled mechanical properties to be compatible with reinforcing bars to BS4449.

### 1.3 Conclusion

It is the opinion of UK CARES that LENTON<sup>®</sup> Standard couplers A12, Position couplers P13 and P14 are satisfactory for use within the stated limits when applied and used in accordance with the manufacturer's instructions and the requirements of this certificate.

A handwritten signature in blue ink that reads "Lee Brankley". The signature is fluid and cursive, with a long horizontal stroke at the end.

L. Brankley  
Chief Executive Officer

November 2019



## 2 Technical Specification

### 2.1 General

LENTON® Standard couplers A12, Position couplers P13 and P14 are for joining deformed Grade B500B and Grade B500C steel reinforcing bars complying with BS 4449.

### 2.2 LENTON® Standard couplers A12

The standard couplers A12 are designed for use where one of the bars to be coupled can be rotated. The 12 mm to 20 mm couplers are a one-piece hexagonal section coupler with a tapered thread machined in each end. The 25 mm to 50 mm diameter couplers are a one-piece circular section with a tapered thread machined in each end.

#### Standard A12 Coupler

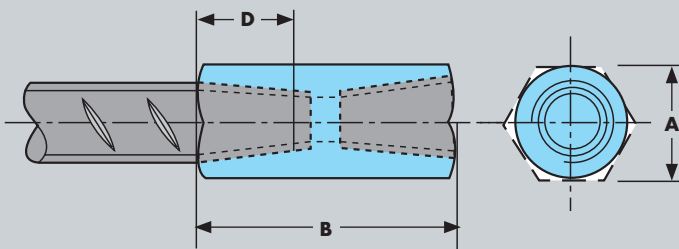

#### KEY

A = diameter  
B = length of coupler body  
D = bar engagement

The dimensions for the A12 coupler are as follows:

Size mm	Part No	Art No	"A" mm	"B" mm	"D" mm	Weight kg	Colour Plug	Installation Torque Nm
12	EL12A12	150010	17*	49	19	0.06	Red	40
16	EL16A12	150030	22*	61	24	0.12	Black	120
20	EL20A12	150050	27*	88	35	0.26	Yellow	180
25	EL25A12	150070	33	96	40	0.35	Red	270
32	EL32A12	150100	42	107	45	0.60	Yellow	300
40	EL40A12	150140	52	131	57	1.12	Green	350
50	EL50A12	150160	64	163	70	2.00	Black	350

Table 1

\*Use hexagonal material (measured across the flats), others use round material

### 2.3 LENTON® Position couplers P13 and P14

The P13 and P14 three-piece position couplers are for use where neither of the bars to be coupled can be rotated. The P13 coupler is specifically used when the bar to be coupled are also restricted in their axial movement. The three components comprise male and female ends with internal taper threads, connected by a female and a male parallel threads and a locknut.

The male section is hexagonal in cross section for 12 mm to 20 mm couplers. The female section is circular in cross section for 25 to 40 mm. The female section is hexagonal in cross section for 12 to 16 mm couplers and circular in cross section for 20 to 40 mm.

**KEY**  
 A = diameter  
 B = length of coupler body  
 D = bar engagement  
 Fc = connector and jam nut (closed position) length  
 Max. Fo = connector and jam nut (fully open position installed) length

**Positional P13 Coupler**

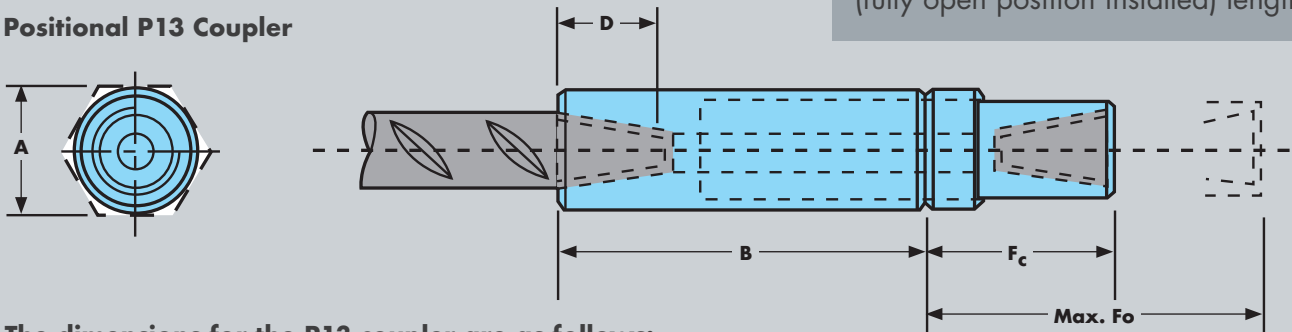

The dimensions for the P13 coupler are as follows:

Size mm	Part No	Art No	"A" mm	"B" mm	"Fc" mm	"Fo" mm	"D" mm	Weight kg	Colour Plug	Installation Torque Nm
12	EL12P13	150190	22*	77	42	85	19	0.29	Red	40
16	EL16P13	150210	27*	88	48	93	24	0.50	Black	120
20	EL20P13	150230	33	112	63	116	35	0.87	Yellow	180
25	EL25P13	150250	41	127	68	128	40	1.31	Red	270
32	EL32P13	150280	52	144	79	144	45	2.38	Yellow	300
40	EL40P13	150320	64	179	91	172	57	4.34	Green	350

**Table 2**

\*Use hexagonal material (measured across the flats), others use round material

The dimensions for the P14 coupler are as follows:

Size mm	Part No	Art No	"A" mm	"B" mm	"Fc" mm	"Fo" mm	"D" mm	Weight kg	Colour Plug	Installation Torque Nm
12	EL12P14	150370	22*	45	42	53	19	0.20	Red	40
16	EL16P14	150390	27*	54	48	59	24	0.35	Black	120
20	EL20P14	150410	33	75	63	79	35	0.64	Yellow	180
25	EL25P14	150430	41	83	68	84	40	0.96	Red	270
32	EL32P14	150460	52	95	79	95	45	1.77	Yellow	300
40	EL40P14	150500	64	114	91	107	57	3.07	Green	350

**Table 3**

\*Use hexagonal material (measured across the flats), others use round material



### 3 Product Performance and Characteristics

Full destructive tests have been carried out to demonstrate compliance with performance requirements defined in CARES Appendix TA1-B including the performance requirements of BS8110 or EC2 for Couplers when used with reinforcing bars to BS4449:

#### CARES APPENDIX TA1-B

- Permanent deformation is less than 0.10mm at 325 MPa in tension or compression.
- Tensile strength is greater than 540 MPa for Grade B500B and 575 MPa for Grade B500C.

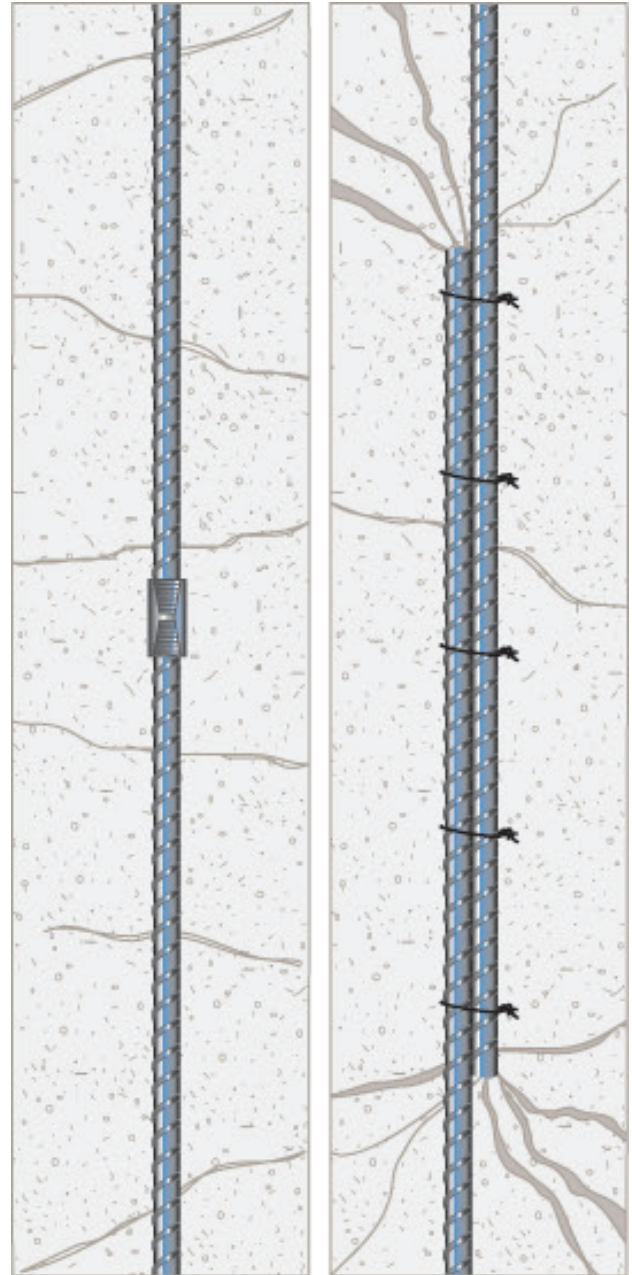

*Mechanical splicing provides the assurance of maintaining load path continuity of the structural reinforcement independent of the condition or existence of the concrete*

*Lap splices rely on bond with the concrete for effective continuity of reinforcement, which can result in localised areas of increased concrete stress that must be considered by the designer*

## 4 Installation

The bars to be threaded must be cut square and threaded, using LENTON<sup>®</sup> equipment and suitably trained and experienced operatives in accordance with LENTON<sup>®</sup> operating instructions. These operators will have received LENTON<sup>®</sup> equipment training.

It is essential that the joints be tightened to the correct torque mentioned in the installation manual, using the appropriate LENTON<sup>®</sup> torque wrench.

### 4.1 LENTON<sup>®</sup> Standard couplers A12

A12 Couplers are for connecting reinforcing bars where one of the bars forming the splice is free to turn. The parts are screwed together by hand and tightened to the correct torque. Where the coupler forms a stop end, it must be torque tightened to the reinforcing bar. When the joint is to be made the continuation bar is screwed into the coupler by hand and tightened to the correct torque. The continuation bar must be able to rotate freely.

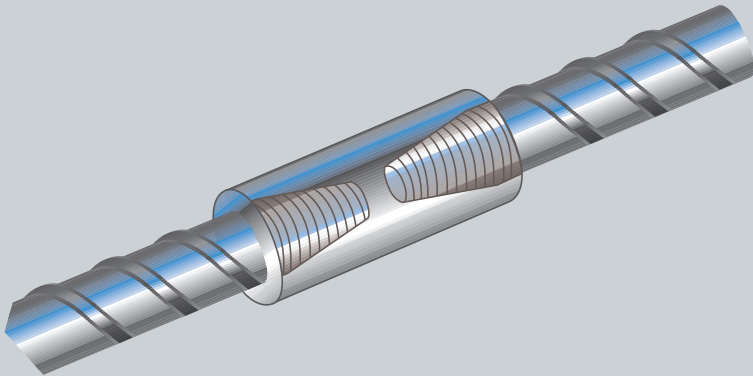

**A12 Coupler**



## 4.2 LENTON® Position couplers P13

P13 Couplers are for connecting cages, crowns of arches, or bars positioned and essentially unable to move. The P13 coupler can be adjusted in length to connect to the second bar. It must be ensured that the coupler is fully screwed together and tightened onto the first bar. The cage or other bar is brought into its final position ensuring that the gap between it and the coupler is not greater than 10-25 mm depending on the size of rebar used. The male part is screwed out to engage the tapered thread of the ongoing bar and then fully tightened. The lock-nut is spun back and fully tightened against the body of the coupler. It must be ensured that the limit groove on the male section is not fully visible above the lock-nut.

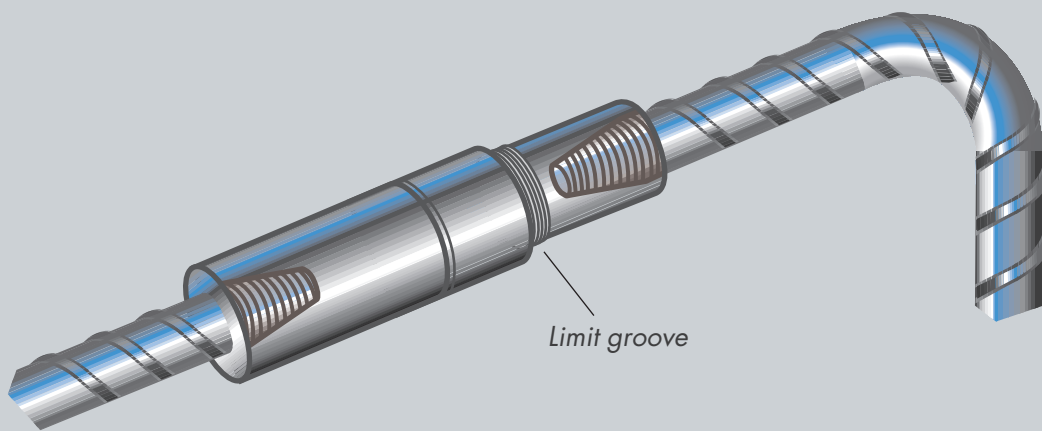

**P13 & P14 Couplers**

## 4.3 LENTON® Position couplers P14

P14 Couplers are for connecting onto a bent bar or a bar that cannot be rotated. It must be ensured that the male part is fully screwed into the female part and the female part is tightened onto the first bar. The taper-threaded bent bar is inserted into the mouth of the coupler as far as possible. The male part is screwed out of the female part to engage the taper-threaded bar and is tightened. The lock-nut is spun back to the coupler body and fully tightened against the coupler body after setting the bent bar to the required position. It must be ensured that the limit groove is not fully visible above the lock-nut.



## 5 Safety Considerations

Care must be taken in handling and installing couplers. Couplers are supplied in containers that have a maximum weight of 25kg. Protective gloves should be worn when handling the containers, threaded bars and installing the couplers.

## 6 Product Testing and Evaluation

LENTON<sup>®</sup> Standard and Position couplers have been tested to satisfy the requirements of BS8110 and EC2 when used with reinforcing bars to BS4449. The testing comprised the following elements:

- Tensile Strength
- Permanent deformation in tension and permanent deformation or effective strain in compression

The products are subject to a programme of periodic testing to ensure that they remain within the performance limits of this technical approval.

## 7 Quality Assurance

LENTON<sup>®</sup> Standard and Position couplers are produced under an ISO9001 quality management system certified by an independent certification body. The quality assurance scheme monitors the production of the couplers and ensures that materials and geometry remain within the limits of this technical approval.



## 8 Building Regulations

### 8.1 The Building Regulations (England and Wales)

#### Structure, Approved Document A

LENTON® Standard couplers A12, Position couplers P13 and P14, when used in EC2 based designs using the data contained within this technical approval, satisfy the relevant requirements of The Building Regulations (England and Wales), Approved Document A.

#### Materials and Workmanship, Approved Document

This technical approval gives assurance that the LENTON® Standard couplers A12, Position couplers P13 and P14 comply with the material requirements of EC2.

### 8.2 The Building Regulations (Northern Ireland)

#### Materials and Workmanship

This technical approval gives assurance that LENTON® Standard couplers A12, Position couplers P13 and P14 comply with the material requirements of EC2 by virtue of regulation 23, *Deemed to satisfy provisions regarding the fitness of materials and workmanship*.

### 8.3 The Building Standards (Scotland)

#### Fitness of Materials

This technical approval gives assurance that LENTON® Standard couplers A12, Position couplers P13 and P14 comply with the material requirements of EC2 by virtue of *Clause 0.8*.

#### Structure

LENTON® Standard couplers A12, Position couplers P13 and P14 when used in EC2 based designs using the data contained within this technical approval, satisfy the requirements of *The Building Standards (Scotland) clause 1*.

## 9 References

- BS 4449: 2005: Steel for the reinforcement of concrete - Weldable reinforcing steel - Bar, coil and decoiled product - Specification
- BS 8110: Part 1: 1997 (Revised 2005): Structural Use of Concrete, Code of Practice for Design and Construction
- BS EN 1992-1-1: 2004 Eurocode 2 Design of concrete structures - General rules for buildings.
- BS EN ISO 9001: Quality management systems - Requirements
- TA1-B Quality and Operations Schedule for the Technical Approval of Couplers for Reinforcing Steel For BS8110 and EN1992-1-1 Applications for Static Loading in Tension and Compression



## 10 Conditions

1. The quality of the materials and method of manufacture have been examined by CARES and found to be satisfactory. This technical approval will remain valid provided that:
  - a The product design and specification is unchanged.
  - b The materials, method of manufacture and location are unchanged.
  - c The manufacturer complies with CARES regulations for technical approvals.
  - d The manufacturer holds a valid CARES Certificate of Product Assessment.
  - e The product is installed and used as described in this report.
2. CARES make no representation as to the presence or absence of patent rights subsisting in the product and/or the legal right of ERICO to market the product.
3. Any references to standards, codes or legislation are those which are in force at the date of this certificate.
4. Any recommendations relating to the safe use of this product are the minimum standards required when the product is used. These requirements do not purport to satisfy the requirements of the Health and Safety at Work act 1974 or any other relevant safety legislation.
5. CARES does not accept any responsibility for any loss or injury arising as a direct or indirect result of the use of this product.
6. This Technical Approval Report should be read in conjunction with CARES Certificate of Product Assessment No 5027. Confirmation that this technical approval is current can be obtained from UK CARES.



Electronic Copy [www.ukcares.com](http://www.ukcares.com)



## UK CARES

Pembroke House  
21 Pembroke Road  
Sevenoaks  
Kent TN13 1XR

Phone: +44(0)1732 450000  
E-mail: [general@ukcares.com](mailto:general@ukcares.com)  
URL: [www.ukcares.com](http://www.ukcares.com)

**Independent Product Assessments  
for the Construction Industry**

Copyright UK CARES ©